

Review Article

WSN and Data Aggregation Techniques in Wireless Sensor Network

Er. Yadwinder Singh^{1*}, Er. Jaspreet Kaur¹, Er. Rupinder Kaur¹¹Assistant Professors IT, Bhai Gurdas Institute of Engineering & Technology, Sangrur, Punjab***Corresponding Author**

Dr. Amanpreet Kaur

Article History

Received: 22.10.2020

Accepted: 06.12.2020

Published: 30.12.2020

Abstract: Wireless sensor network are the collection of hundreds and thousands of tiny, battery powered sensor nodes. Sensor's nodes co-operatively send the sense data to base station. Wireless sensor network has several applications like habitat monitoring, building monitoring, health monitoring, military surveillance and target tracking. Sensor nodes have limited energy and bandwidth. As sensor nodes are battery driven, an efficient utilization of power is essential in order to use the networks for long duration. Hence, network lifetime is most challenging task and it became necessary to reduce data traffic inside sensor networks, reduce amount of data that need to send to base station. This reduction of communication data extends the network lifetime and it is possible only if sensor nodes perform data aggregation instead of directly sending the sensed data to sink (Base station). This paper presents various data aggregation techniques in wireless sensor network and a novel Data Routing for In-network aggregation called DRINA. The main goal of data aggregation is to gather and aggregate data in energy efficient manner in order to enhance the network life time.

Keywords: Cluster Head, Data aggregation, In network data aggregation, Wire.

INTRODUCTION

The wireless sensor network is an Ad-hoc network. It consists of small light weighted wireless nodes called sensor node, deployed in physical or environmental condition. It measured parameters such as sound, pressure, temperature and humidity. Sensor is a transducer that converts physical phenomenon e.g., light, motion, vibration, and sound into electrical signals [1]. These sensor nodes deployed in large or thousand numbers and collaborate to form an ad hoc network capable of reporting to data collection sink (Base station). In some applications sensor nodes may be allowed to move or change their position, as the sensor nodes are application specific. The main task of wireless sensor network can be divided into three categories: -Sensing, Processing and Acting [2]. The sensor periodically senses the data, process it and transmit it to the base station. Sensor nodes are randomly deployed in a network and data from different sensor nodes get collected by base station. The user can view the data collected by base station through the use of internet [7] (fig. 1). Section II describe the various design issues in Wireless Sensor Network. Section III presents the Data aggregation approaches in Wireless Sensor Network.

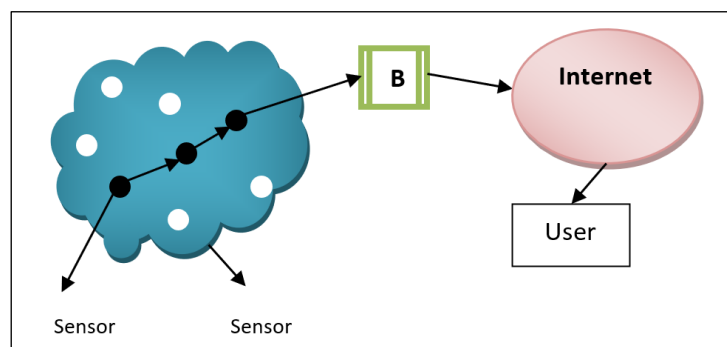

Fig. 1: Sensor network

Copyright © 2020 The Author(s): This is an open-access article distributed under the terms of the Creative Commons Attribution 4.0 International License (CC BY-NC 4.0) which permits unrestricted use, distribution, and reproduction in any medium for non-commercial use provided the original author and source are credited.

Components of Sensor Node: -A sensor node is made up of four components [3].

- a) A sensing unit.
- b) Processing unit.
- c) Transceiver.
- d) Power unit.

They may also have application dependent additional components such as a location finding system , a power generator and a mobilizer (Fig. 2). Sensing units are composed of two sub-units: Sensor and ADC (analog to digital convertor). The analog signals produced by the sensor based on observed phenomenon are converted into digital signals by ADC and then fed into the processing unit. The processing unit, which is generally associated with the a small storage unit manage the procedures that make the sensor node collaborate with the other nodes to carry out the assigned sensing tasks. A transceiver unit connects the node to the network . One of the most important component of sensor node is the power unit. Power units may be supported by a power scavenging unit such as solar cell. Most of the sensing network routing techniques and sending tasks require the knowledge of location with high accuracy. Thus it is common that a sensor node has a location finding system. A mobilizer may sometimes be needed to move sensor node when it is required to carryout the assigned task.

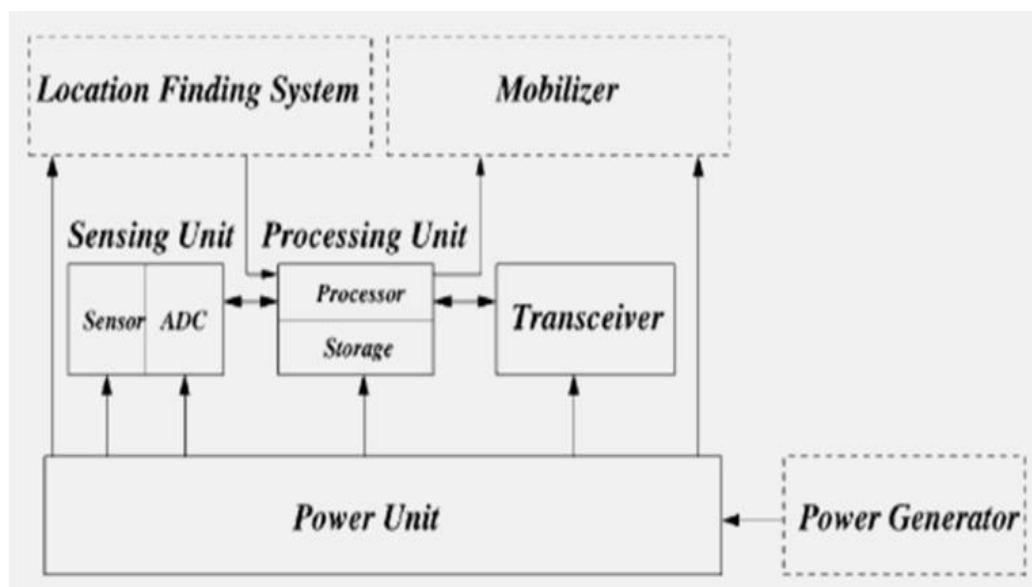

Fig. 2: Components of sensor node

Applications [1][2]

The main application regions of wireless sensor network as follows: -

- The simplest application includes the measurement and monitoring of physical phenomenon like temperature, pressure and humidity etc.
- **Area Monitoring:** -The sensors are placed in the region to be monitored like in detecting the movement of vehicles.
- **Environment Sensing:** -This include the measurement of harmful gases in the atmosphere, to detect the forest fire by measuring temperature, humidity, gases which are produced by fire in trees and vegetation. Even the small movement of soil can be detected.
- **Defense and Military application:** - In military they are used to monitor if there is any illegal entry of any person, arms etc. Networks can be deployed in target area to gather the battle assessment data also to watch the activities of the opposing forces.
- **Societal Application:** -It involves movement of school going children; allow end users to handle and manage home devices and appliances locally and remotely, tracking doctors and patients inside a hospital etc.
- **Industrial Monitoring:** -Include machine health monitoring and based on that maintenance is done. Also include data logging which include collection of data to monitor the environment conditions like level of water in tank, in nuclear plant to see well working of the system.

II. Design Issues

Power Consumption: -Sensor nodes are very small in size and equipped with limited power source. In wireless sensor network power conservation and power management takes an additional importance. Many powers aware algorithm and

protocols have been developed in various researches [2]. Power consumption can be divided into three domains: - Sensing, Communication and processing.

Localization [3]: -As wireless sensor network are ad hoc networks in which nodes are deployed manually, so the nodes do not have the knowledge about their position. The problem of determining the location of node is known as localization. This problem can be solved by

- GPS.
- Beacon nodes.

Other techniques such as Beacon based distributed algorithm, Centralized localization algorithm, relaxation based distributed algorithm [1] can also be used.

Sensor Network Topology: -In network hundreds to several thousands of nodes are deployed. We examine issues related to topology change in three phases [1]: -

a). Pre-Deployment and Development Phase: - Sensor nodes can either be placed in bulk or one by one in a network. Nodes can be deployed by;

- Placing one by one either by human or a robot.
- Dropping from a plane.
- Placing in factory.
- Throwing from a ship board

b). Post deployment phase: -After deployment due to change in sensor node's position, reachability, availability, energy etc. the topology changes.

c). Re-deployment of additional node phase: -Malfunctioning nodes can be replaced by the re-deployment of additional sensor nodes. Addition poses a need to re-organize the network.

Environment: - Sensor nodes are deployed either very close or inside the phenomenon to be observed. They may be working

- In busy intersection.
- At the bottom of an ocean.
- In the interior of large building.
- In a home or large building.
- Attached to fast moving vehicles.

Security: - Security is the most important aspect required in any network. The security properties such as authentication, confidentiality, data integrity availability, key establishment must be possessed by a network.

Quality of service: - Quality of service is the measure of level of service provided by a sensor network to the user. Quality of service is characterized by maximum throughput, minimum delay, and bandwidth utilization. In wireless sensor network traffic is non uniform as data aggregation occurs in many nodes. So, Quality of service should be able to deal with non –uniform traffic.

III. Data Aggregation approaches in wireless sensor network

In the context of wireless sensor network, Data aggregation refers to the different ways in which the interior nodes combine data gathered from different source nodes and forward the data toward sink node [4]. A key aspect of in-network aggregation is the synchronization of data transmission among the nodes. There are two approaches for in-network data aggregation: -

- With size reduction
- Without size reduction

In-network aggregation with size reduction refers to the process of combining and compressing the data packets received by a node from its neighbors, in order to reduce the packet size to be forwarded toward sink [5].

In-network aggregation without size reduction refers to process of merging data packets received from different neighbors into a single data packet but without processing the value of data.

Data aggregation in sensor network is shown in fig. 3, Data from node A and B get aggregated at node E. Similarly, data from node C and D are aggregated at node F and finally at node G resultant aggregation occurs and results are transmitted to sink.

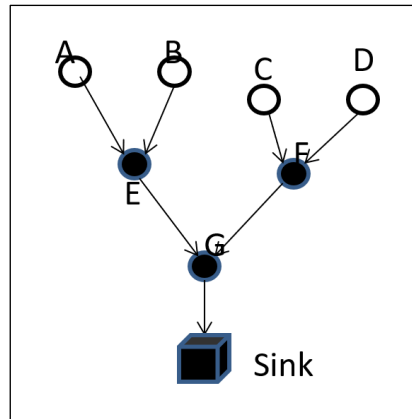

Fig. 3: Data Aggregation in WSN

Three main timing strategies are found in the literature [5] are:

- **Periodic Simple Aggregation:** Each node has to wait for pre-defined period of time while aggregating all received data packet and then, forward a single packet with the result of the aggregation.
- **Periodic Per-Hop Aggregation:** Quite similar to previous approach, but the aggregated data packets are transmitted as soon as node receives packets from its children.
- **Periodic Per-Hop Adjusted Aggregation:** Adjusts the node transmission time according to node's position in aggregation tree.

Data Aggregation Approaches: -

- A. Structure free approach
- B. Structured approach
 - Tree based approach
 - Cluster based approach

Structure Free Approach: -A wireless sensor network is a multi-hop Ad-hoc network, no infrastructure is available to connect the nodes. In multi-hop communication intermediate nodes become relay points. WSNs are generally deployed randomly so, they are by nature structure free [4]. The typical communication architecture for structure free data aggregation is basic client server architecture. There is one server and several clients, which are connected to it. Clients are the sensor nodes and server is the sink. Hence, the communication in WSNs follows the client server architecture by nature. This method is very useful in event based application where event region changes very frequently and if we use structure-based approach then we have to maintain the structure again and again. There are two main challenges in this approach [4]:

- a) As there is no pre constructed structure, routing decisions for the efficient data aggregation to be made on-the-fly.
- b) As nodes do not explicitly know their upstream nodes, they cannot explicitly wait on data from any particular node before forwarding their own data.

The benefit of this approach is that we don't have to maintain the structure all the time whereas in structured environment we have to reconstruct the structure at the time of when some nodes fail due to energy constraints.

Structured Approach: - The most popular structure-based data aggregation mechanisms are as following:

Tree Based Approach: -In tree-based approach the sensor nodes are organized into a tree, where data aggregation is performed at intermediate node along the tree. Sink node consider as a root and source node consider as leaves. This approach is suitable for applications which involve in network data aggregation. This approach has some drawbacks, when a packet is lost at certain level of tree data from whole sub-tree will be lost as well. In most cases tree-based protocol builds a traditional shortest path routing tree. SPT algorithm use simple strategy to build a routing tree. Different data aggregation algorithms were proposed such as directed Diffusion algorithm in [8], Tiny Aggregation algorithm in [8] and Greedy Incremental Tree in [8].

Cluster Based Approach: -Cluster based approach is hierarchical approach. In this approach, whole network is divided into several clusters. Each cluster has a cluster head which is elected among cluster members [6, 9]. Cluster-heads perform data aggregation of data received from cluster members locally and then transmit the result to base station (sink). The cluster heads can communicate with the sink directly via long range transmissions or multi hopping through other cluster heads. Data aggregation over cluster based WSN classified into three categories [8]:-

- Efficient static clustering centric data aggregation.

- Data aggregation centric cluster based.
- Event centric data aggregation over cluster based WSN.

In the Low-Energy Adaptive Clustering Hierarchy (LEACH) algorithm [6, 9, 10] clustered structures are exploited to perform data aggregation. In this algorithm, cluster heads can act as aggregation point and they communicate directly to the sink node. This algorithm is based on the assumption that sink can be reached by any node in only one hop, which limits the size of network for which such protocol can be used. The Information Fusion-based Role Assignment (InFRA) algorithm builds a cluster for each event including only those nodes that were able to detect it. Then, cluster-heads merge the data within the cluster and send the result toward the sink node. The InFRA algorithm aims at building the shortest path tree that maximizes information fusion.

IV. DRINA- Data Routing for In-network Aggregation for WSN

The main goal of DRINA is to build a routing tree with the shortest path that connect all source nodes to the sink. DRINA considers the following roles in the routing infrastructure [6]:-

Collaborator: - A node that detect an event and report the gathered data to coordinator node.

Coordinator: -A node that detect an event and is responsible for gathering data sent by collaborator node, aggregating them and sending the results toward the sink node.

Sink: - A node interested in receiving data from set of coordinator and collaborator.

Relay: - A node that forward data towards the sink.

The DRINA algorithm can be divided into three phases. In Phase 1, the hop tree from the sensor nodes to the sink node is built. Phase 2 consists of cluster formation and cluster head election among the nodes that detected the occurrence of a new event in the network. Finally, Phase 3 is responsible for both setting up a new route for the reliable delivering of packets and updating the hop tree. Complete algorithms for these phases are described in [6].

Selection of Cluster Head: -In order to elect the cluster head in energy efficient manner residual energy is calculated instead of either considering the energy of node or distance of node from the sink. When the cluster head is elected on the basis of higher energy only, then there is possibility that elected node might be far away from sink. This in turn consume much resources such as energy to transfer aggregate data towards sink. Similarly, when cluster head is elected on the basis of smallest distance form sink, then there is possibility that elected node might have insufficient energy to carry out all the required functioning. Residual energy is computed as: -

$$\text{Residual energy} = \frac{\text{Energy of node.}}{\text{Distance}}$$

Where

Energy of node is the energy of the node whose residual energy is to be calculated. Distance is the total distance between the node whose residual energy is to be calculated and destination.

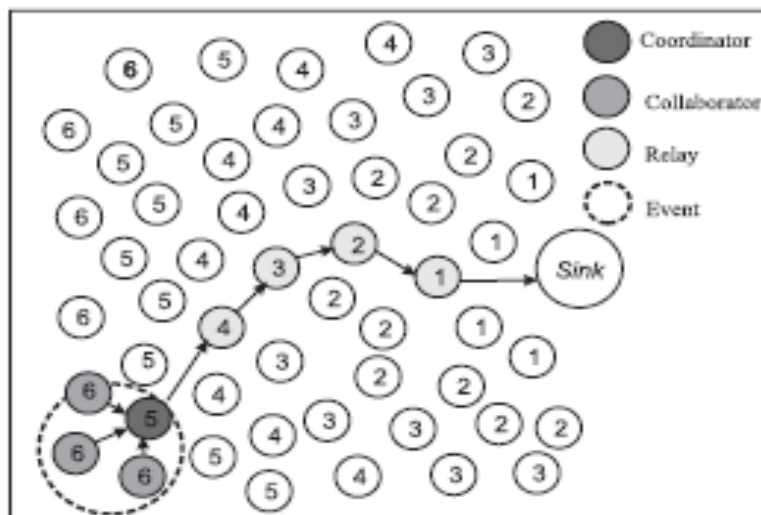

Fig. 4: Example of routing tree to event

Cluster head by using the SPT (Shortest path Tree) select a path with shortest distance to destination. Once the shortest path is found, cluster head forwards the packets to destination through that path (Fig. 4).

V. Advantage and Disadvantage of Data Aggregation

Advantages: -

- a) Data aggregation enhance the robustness and accuracy of information.
- b) Redundancy exists in the data collected from sensor nodes easily get reduced with data fusion processing.
- c) Reduces the traffic load and conserve energy of the sensor.

Disadvantages: -

- a) The cluster head means data aggregator nodes send fuse these data to the base station. This cluster head or aggregator node may be attacked by malicious attacker.
- b) If a cluster head is compromised, then the base station (sink) cannot be ensuring the correctness of the aggregate data that has been send to it.
- c) Another drawback is existing systems are several copies of the aggregate result may be sent to the base station (sink) by uncompromised nodes. It increases the power consumed at these nodes.

VI. Simulation Tools

Number of tools which are used for simulation of the wireless sensor network are as following:

- A. **NS-2**: -NS2 is the abbreviation of Network simulator version two, which first been developed by 1989 using as the REAL network simulator. NS-2 [11] is non-specific network simulators which supports a wide range of protocols in all layers. NS-2 is discrete event simulator which is developed in C++. Otcl [12] is used as configuration and script interface in NS-2. It provides the most complete support of communication protocol models, among non-commercial packages. WSN and ad-hoc specific protocols such as directed diffusion [13] or SMAC [14]
- B. **OMNET++** [15]: - OMNET++ is easy simple modular discrete event simulator and implemented in C++. Powerful GUI library for animation and tracing and debugging Support is provided by this tool. Users can run OMNeT++ simulator on Linux Operating Systems, Unix-like system and Windows. The major drawback of OMNET++ is the lack of available protocols in its library. Mobility framework released for OMNET++ [16] and it can be used as a starting point for WSN modeling.
- C. **Ptolemy II** [18]: - Different models of simulation paradigms are supported by Ptolemy II. Modeling, simulation and design of concurrent, real-time, embedded systems are addressed by this. By sub classing base classes of the framework or by combining existing Ptolemy models, models can be developed.
- D. **SSF Net** [17]: - Scalable Simulation Framework (SSF) is set of Java network models. Portability between compliant simulators is assured by specification of a common API for simulation. Multiple Java and C++ implementations of SSF are available.

VII. CONCLUSION

Wireless sensor network has many applications. Life time and overall performance of the network is affected by issue power consumption so it becomes major issue in the wireless sensor network. In this paper we discuss the data aggregation are one of the important techniques for enhancing the life time of the network. Efficient data gathering techniques and routing protocol can be used in order to minimize the energy consumption. Data aggregation is the one of the main methods used to reduce the power consumption in WSNs. It deals with the reduction of the number and size of the communicated messages.

REFERENCES

1. Akyildiz, I. F., Su, W., Sankarasubramaniam, Y., & Cyirci, E. (2002). Wireless sensor networks: A survey. *Computer Networks*, 38(4), 393–422.
2. Nirvika, C., Vyavahare, P. D., & Rekha, J. (2013). Wireless Sensor Network –A Survey”, *International Journal on Computer Science and Engineering (IJCSE)*, 5(07). ISSN: 0975-3397.
3. Jonathan, B., & Christopher, T. Localization in Sensor Network” Computer Science & Artificial intelligence Labortory, *Massachusetts Institute of Technology Cambridge, MA 02139*, {taylorc, bachrach}@mit.edu
4. Vaibhav, P., Amarjeet, K., & Narottam, C. (2010). A review on data aggregation techniques in wireless sensor Network. *Journal of Electronic and Electrical Engineering*, 1(2), 01-08. ISSN: 0976–8106 & E-ISSN: 0976–8114,
5. Nandini, S. P., & Patil, P. R. (2010). Data Aggregation in Wireless Sensor Network. *IEEE International Conference on Computational Intelligence and Computing Research*, ISBN: 97881 8371 362 7.
6. Villas, L. A., Boukerche, A., Ramos, H. S., De Oliveira, H. A. F., De Araujo, R. B., & Loureiro, A. A. F. (2012). DRINA: A lightweight and reliable routing approach for in-network aggregation in wireless sensor networks. *IEEE Transactions on Computers*, 62(4), 676-689.
7. Sushruta, M., & Hiren, T. (2012). Features of WSN and Data Aggregation techniques in WSN: A Survey”, *International Journal of Engineering and Innovative Technology (IJEIT)*, 1(4). ISSN: 2277-3754.
8. Ahmad, S., Leila, M.-B., Rana-Rahim, A., & Dominique, G. (2010). *Data Aggregation in WSN: A Survey*, 2010 Nova Science Publishers, Inc. 4(4). ISSN: 1935-2441,

9. Preethi, Y. R., Manjunath, C. R., & Manohar, M. (2013). Data Routing in In-network Aggregation in WSN: a Cluster Based approach. *International Journal of Modern Engineering Research (IJMER)*, 3(3), 1636-1640. ISSN: 2249-6645.
10. Handy, M. J., Haase, M., Timmermann, D. (2002). Low Energy Adaptive Clustering Hierarchy with Deterministic Cluster-Head Selection. *Fourth IEEE Conference on Mobile and Wireless Communications Networks*, Stockholm, erschienen in Proceedings, S. 368-372, ISBN 0-7803-7606-4, World Scientific Publishing Co.
11. The Network Simulator, NS-2 [Online] Available: <http://www.isi.edu/nsnam>.
12. MIT Object Tcl. [Online]. Available: <http://bmrc.com>
13. Intanagonwiwat, C., Govidan, R., Estrin, D., Heidemann, J., & Silva, F. (2003). Directed diffusion for wireless sensor networking. *IEEE/ACM Transactions on Networking*, 11(1), 2–16.
14. Ye, W., Heidemann, J., & Estrin, D. (2004). Medium Access Control with Coordinated, Adaptive Sleeping for Wireless Sensor Networks. *ACM/IEEE Transactions on Networking*, 12, 493–506.
15. OMNET++ discrete event simulator. [Online]. Available: <http://www.omnetpp.org>
16. Mobility Framework for OMNET++. [Online]. Available: <http://mobility-fw.sourceforge.net>
17. Scalable Simulation Framework (SSF). [Online]. Available: <http://www.ssfnet.org>
18. Potemyl. Heterogenous model and design. [Online]. Available: <http://potemyl.eecs.berkeley.edu/Ptolemy>